

2800 SERIES TRAILER SUPER TWIN SCREW VERTICAL MIXERS



Patz[®]

EXTREME DUTY SUPER TWIN

Capacity of a TRIPLE, *Precision Mix* of a TWIN,
and *Efficiency* of a SINGLE TMR!



THE MOST TRUSTED MIXER THE MOST VALUED MIX

- ✓ **Consistent** TMR beyond demo and after the sale - precision feeding for service life.
- ✓ **Capacity** with Balanced Flow Technology™ - no dead spots at struck height!
- ✓ **Cleanout** minimizes residue carryover for balanced rations, batch integrity, and nutrient cost control.

FEEDING IS BELIEVING!
Schedule a DEMO Today!

FEEDINGSOLUTIONS
www.patzcorp.com

INVESTMENT FLEXIBILITY
Ask Dealer for Financing Details



2800 Series Trailer Super Twin Screw Vertical Mixer

BALANCED FLOW™ TECHNOLOGY



PROVEN, PATENTED PRODUCTIVITY

Patz exclusive design engineering balances horizontal processing and vertical mixing. The continuous, controlled motion ensures a thorough and consistent mix with superior clean-out.

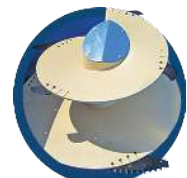

1. Precision-fitted, AR400 - Component Vortex®-E screw is specifically designed for high performance/high density rations in high-capacity vertical mixers. This Extreme Duty screw is equipped with more flighting capacity and an expanded screw deck for increased feed flow along higher sidewalls.

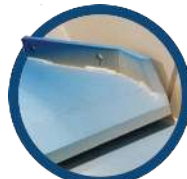

2. Welded, AR400 shear plow wing tight tolerance cleans the tub sidewall for maximum mixing action and cleanout with minimal torque.

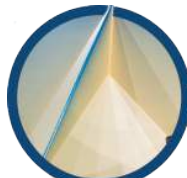

3. Contoured patented baffles balance horizontal processing and vertical mixing action in twin and triple screw vertical mixers.



4. The original, stainless steel tub-mounted magnet with patented, reticulum retention design removes tramp metal without restricting feed flow. Feed safer and inspect frequently with quick-opening access.



5. Reversible restrictor plates are located on front left and right rear of tub. Adjust in or out to control forage flow and particle size.

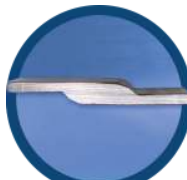

6. Surface-primed, overlapping steel tub-ends and sidewalls with reinforced exterior anchor and interior seam welds; sand-blasted and primer finish with high-gloss hardened, premium paint.



2800 Series Trailer Super Twin Screw Vertical Mixer

FEED THE POTENTIAL™

THE PROFESSIONAL PRODUCER'S CHOICE IN TMR

Feed is 65% of operating costs, make every ingredient count with a consistent TMR from start to finish!

- Feed a wider variety of ingredients
- Maximize dietary fiber with large squares and wet or dry standard and high-density round bales
- Batch size flexibility for special needs or pre- and post-fresh groups



UNLEASH THE TOTAL MIX POTENTIAL OF YOUR FEED, YOUR HERD, AND YOUR MANAGEMENT WITH PATZ VERTICAL MIXERS!



Gray arrows indicate direction of screw rotation.
Green arrows indicate Balanced Flow™ of feed



Highest rated consistency throughout service life in the industry in independent TMR audits!

- Minimize sorting and reduce refusals with a palatable, well-blended TMR
- Increase dry matter intake (DMI) with uniform theoretical length of cut (TLC)
- Improve TDN utilization by preserving physically effective fiber (peNDF) integrity
- Ensure precision feeding program accuracy with Patz superior cleanout

2800 Series Trailer Super Twin Screw Vertical Mixer

Standard Features

Units Available: 1300, 1475, and 1600 cu. ft. (36.8, 41.8, and 45.3 m³)



EXTREME DUTY DRIVETRAIN ENGINEERING

Overload Protected, Poly-Sheilded ASABE/ISO/CE Safety Guarded/Harnessed Drive-Line

1 Primary Drive-Line

- Dual-Yoked **Constant Velocity (CV) Joint** PTO minimizes vibration during in-motion pivot operation. Available in:

- 1 3/4 inch - 20 Spline (45 mm) PTO

- Synchronized **Cut-Out Clutch** protects drive-line and tractor PTO from shock loads and eliminates shear-pins

2 Patented T3 Autoshift Transmission system backed by 5 Year Pro-Rated Warranty

3 Tertiary Drive-Line with Secondary Cut-Out Clutch

4 Extreme Duty 90° Planetary Gearbox backed by a 5 Year Pro-Rated Warranty

- #### 5 Independent nested oil reservoirs with dip-stick cap to monitor planetary gearbox oil level, centrally located for routine maintenance

DURABLE TUB AND TRAILER DESIGN

- #### 6 1/2 inch (13 mm) - Reinforced, Welded Gusset Top Rim

- #### 7 Optional 1475 ft³ and 1600 ft³ size kits for adding mixing capacity up to 1600 cubic feet

- #### 8 3/8 inch (9 mm) XH - Overlapping, surface-primed, 58-80K PSI Ultimate Tensile Strength (UTS) sidewalls reinforced with exterior anchor and interior seam welds, finished with high-gloss hardened, premium paint

- #### 9 Reversible restrictor plates are located on front left and right rear of tub. Adjust in or out to control forage flow and particle size.

- #### 10 Integrally formed, reinforced tub floor provides the solid structure for mixer construction minimizing flex and fatigue:

- 3/4 inch (19 mm) - Solid Steel **Base Plate** with Beveled Sidewall Foundation Joist
- 1/2 inch (13 mm) - Welded Steel **Cantilever Cross Members** evenly distribute orbital mixing torque
- 3/4 inch (19 mm) - Welded Steel Sectional **Sub-Floor** forms a rigid 1 1/2 inch (38 mm) - Planetary Gearbox Mount

- #### 11 4 Independent Weigh Bars anchor tub to trailer for accuracy, serviceability, and reliability

- #### 12 1/2 inch x 8 inch x 12 inch (12.7 mm x 203.2 mm x 330.2 mm) - Rectangular **Steel Tube Frame** equalizes load weight from hitch to taillight

- #### 13 1/2 inch x 8 inch x 12 inch (12.7 mm x 203.2 mm x 330.2 mm) - **Underslung "A" Frame Tongue** design provides 48 inches (121.9 cm) of strengthened load carrying capacity and turning torsion resistance with a narrow turning radius to safely manage tongue weight

- #### 14 Conventional Dual **Walking Tandem Suspension** on four heavy duty hubs, with choice of:

- (4) 445/50 R22.5 Super Single Flotation Tires
- (8) 315/80 R22.5 All-Position, Conventional Duals

Tractor-integrated, hydraulic disc brakes, with wheel chocks and stowage

- #### 15 Safely view Patz exclusive mixing action from front viewing platform with treaded ladder, hydraulic line stowage, and auxiliary indicator mount

- #### 16 LED taillights with 7-pin ISO connector for safe, visible transport

Some variations may apply to standard and optional equipment for each unit size. Please refer to specifications page for more information.

2800 Series Trailer Super Twin Screw Vertical Mixer T3 TRANSMISSION

PRECISION TMR AUTOSHIFT TRANSMISSION

You may never mix a ton of feathers and a ton of bricks – but you do know they would mix differently. Density determines feed flow and friction, and friction equals torque. Weight is static – torque is movement. Don't just weigh your TMR – mix it with torque!

The next generation in precision feeding, Patz **patented** torque-controlled autoshift technology promotes TMR quality while protecting tractor PTO. **Patented** transmission control system design utilizes real-time operating torque to automatically shift up-or-down – and now shift into neutral (T3 only)– for optimal mixing speed and efficiency.

Patz precision TMR autoshift packages include:

- On-board Control Module with 3.5 inch high resolution color display for programming, manual functions, and real time diagnostics
- Operating Mode Options offers unparalleled flexibility with three (3) transmission operating modes Fully Automatic; Semi-Manual for manual control; and Custom Automatic with up to five (5) custom automatic shift point sequences for special rations



PATENTED AUTOSHIFT TECHNOLOGY EXCLUSIVE TO PATZ!



T3 Autoshift

3-Speed transmission with neutral adds a low 1st gear for start-up under load, optimal mixing speed in 2nd gear, and a high 3rd gear for efficient feeding and cleanout.

Patz exclusive T3 features include:

- Built-in kinetic soft start technology protects tractor PTO clutch
- T3 defaults to neutral when started allowing primary driveline to free spin to preset minimum RPM before engaging transmission under load
- Low first (1st) gear eliminates full-torque hard starts or the need to over mix and over process the ration during transport
- Electronic buffered Modulated Shifting stabilizes shift points and reduces torque for smooth transition when shifting
- Timed-Neutral optimizes particle size and prevents over-processing through a programmable revolution counter, shifting the transmission to neutral when mix is complete



2800 Series Trailer Super Twin Screw Vertical Mixer

Optional Features



FRONT DISCHARGE CONVEYOR

Tub-mounted cross conveyors weigh material on conveyor. Flat cross conveyor include RH, LH, reversing, and sliding discharge options. Extreme duty chain and slats.



SIZE KIT & SIZE EXTENSIONS

Increase mixing capacity with choice of:

- 9½-inch side extension with steel ends and rugged rubber sides.
- 9½-inch all-steel size kit increasing capacity to 1475 cu. ft.
- 16-inch all-steel size kit increasing capacity to 1600 cu. ft.



MIXING KNIVES

Install genuine Patz knives to manage long fiber in your ration. Pair Patz patented RAPTOR® bale knife with our custom hardened Tungsten/Carbide serrated knives in a variety of sizes.

KNIFE OPTIONS

AR400 RAPTOR®
4¼, 4¾, 5½, 7½, 10-inch

AR400 or Tungsten/
Carbide Serrated
12 and 21½ inch

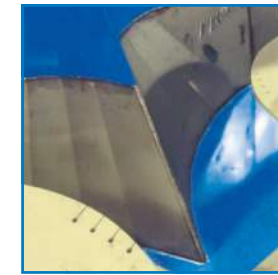

TUB LINER

Choice of ⅜ inch thick steel or 11 gauge stainless steel for additional wear protection of mixer tub.



SIDE DISCHARGE(S)

Side doors can be equipped with a chain conveyor discharge with collapsible steel sides. Available in hydraulic or manual operation. Features 20% larger doors and discharges compared to other Patz mixers.

REAR COMMODITY

Pre-mix commodities once and empty into a storage bin. Back mixer into narrow spaces for emptying, and streamline your mixing process.



PATENTED MAGNET

This Patz Exclusive patented magnet is strong enough to pull tramp metal from the ration while mixing or feeding.

MAGNET OPTIONS

Tub Magnet
Magnet that is mounted into the tub wall.
Discharge Magnet
Attaches to inside of discharge shrouding.

2800 Series Trailer Super Twin Screw Vertical Mixer Specifications

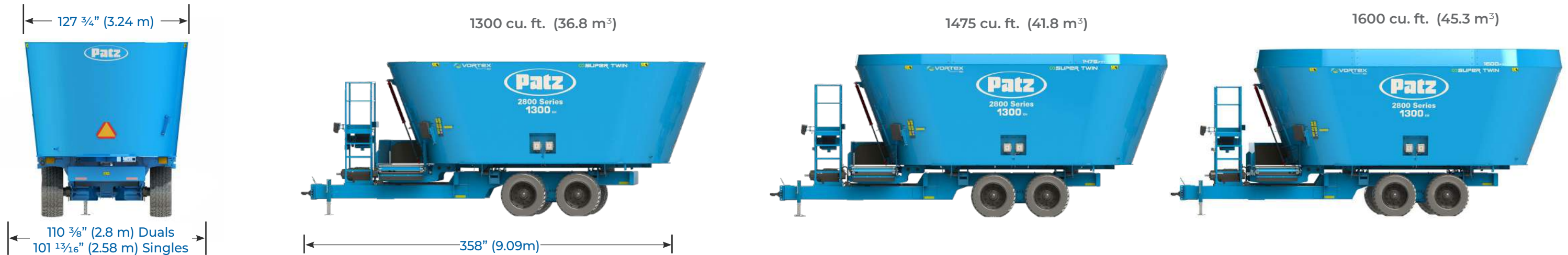

2800 Series Vortex®	U/M	1300XH	1475 FT ³ Size Kit	1600 FT ³ Size Kit
Mixing Capacity	ft ³ /m ³	1,300 (36.8)	1,475 (41.8)	1,600 (45.3)
Empty Weight	lbs (kg)	32,000 (14,515)	32,610 (14,792)	32,882 (14,915)
Max Load @ 35 lb/ft ³	lbs (kg)	45,500 (20,638)	51,625 (23,417)	56,000 (25,401)
Max Gross Weight	lbs (kg)	77,500 (35,153)	84,235 (38,208)	88,882 (40,316)
Overall Height	in (m)	Singles 137 3/8" (3.49); Duals 138 17/32" (3.52)	Singles 146 5/8" (3.72); Duals 147 25/32" (3.74)	Singles 153 3/8" (3.89); Duals 154 17/32" (3.91)
Floor Thickness	in (mm)	3/4 (19)		
Sidewall Thickness	in (mm)	3/8 (9)		
Door Opening Height x Width (Rear/Front)	in (mm)	34 x 47 (864 x 1,194)		
Door Opening Height x Width (Side - 2 Locations)	in (mm)	39 x 34 (991 x 864)		
Viewing Platform		Front w/ Left Access		
Screw Flighting Thickness	in (mm)	3/4 (19)		
Screw Height x Diameter	in (mm)	64 x 108 (1,636 x 2,743) or 74 x 108 (1,880 x 2,743)		
Knife Positions Per Screw		9 / 11		
Operating Speed	RPM	700 - 1,000		
Drive Package		T3 Autoshift		
Minimum PTO HP (Continuous Run)	HP	250		
Trailer Type		Split Dual; Tandem Walking Beam		
Scale System		4-Point		
Tires		(4) 445/50 R22.5 Single (8) 315/80 R22.5 Dual Tires		

OPTIONS				
Mixer Screws Mixer Knives	Side Extensions Size Kits	Discharge Chute w/ or w/o Magnet Discharge Conveyor Tub Mounted Magnet	Scale Systems - Digi-Star® - dinamica generale® - Weigh-Tronix®	Camera Package Planetary Cooling System Hydraulic Control Center



CAUTION: Never operate Patz equipment without all shields and guards in place. **Safety Is No Accident.** Before operating any piece of equipment, be sure to read and understand the operator's manual. This manual should be kept with the machine at all times. Additionally, make sure all safety shields and devices are functioning properly and are securely in place. Specifications and prices subject to change without notice.



Patz Corporation • Pound, Wisconsin USA
Ph: (920) 897-2251 • info@patzcorp.com • www.patzcorp.com

